

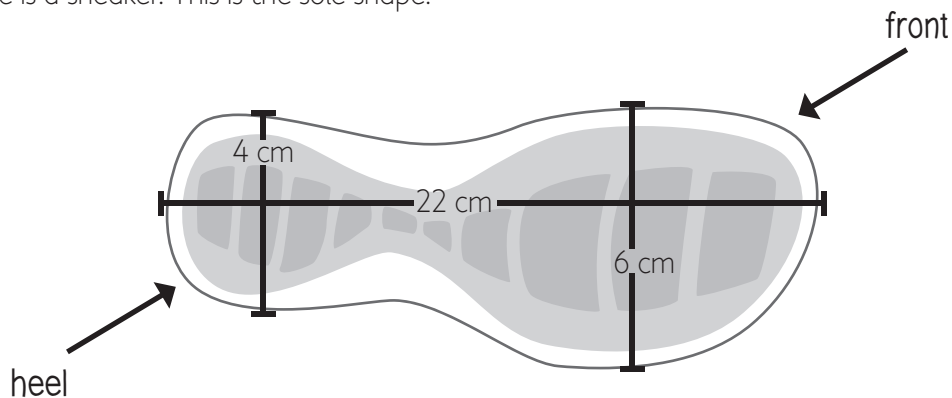

MG2 Measurement with centimetres

- 1 Borrow a shoe each from 2 classmates. Place each shoe on a piece of paper and trace around it. Measure and write the dimensions of each shoe, using centimetres as shown in the example below. Also, draw the side view of each shoe.

Melissa's shoe is a sneaker. This is the sole shape.



It is 22 cm long, 4 cm wide at the heel and 6 cm wide at the front.

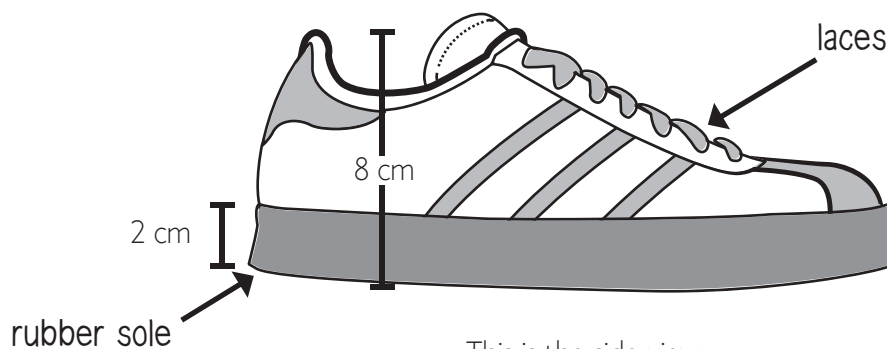

This is the side view.

It is 8 cm high at the ankle. The rubber sole is 2 cm wide.

- 2 Be a shoe designer. Design your own sports shoe. Draw it to size. Label any special features and write the dimensions in centimetres.